

---

**COMPRESSOR, AIR ROTARY,  
DIESEL ENGINE DRIVEN, SKID MOUNTED  
125 cfm at 100 psig  
(4310-01-348-6951)  
MODEL 16MS125**

References: TM 9-4310-397-14 and TM 9-4310-397-24P

**REPORTING ERRORS AND RECOMMENDING IMPROVEMENTS**

You can help improve this manual. If you find any mistakes, or if you know of a way to improve these procedures, please let us know. Mail your letter or DA Form 2028 (Recommended Changes to Publications and Blank Forms) directly to: Commander, US Army Aviation and Troop Command, ATTN: AMSAT-I-MP, 4300 Goodfellow Blvd., St. Louis, MO 63120-1798. You may also submit your recommended changes by E-mail directly to <mpmt%avma28@st-louis-emh7.army.mil>. A reply will be furnished directly to you.

---

**DISTRIBUTION A: Approved for public release; distribution is unlimited**

**NOTES**

The lowest level maintenance is Unit and is indicated by the symbol (O). Intervals and the related man hour times are based on normal operation. The man-hour time specified is the time required to perform all the services prescribe for a particular interval. The interval shall be changed to compensate for abnormal operation and severe operating conditions or contaminated lubricants. The interval may be extended during periods of low level activity, commensurate with adequate preservation precautions.

Oil filters shall be serviced/cleaned/changed as applicable, when:

- a. They are known to be contaminated, or clogged;
- b. Service is recommended by AOAP laboratory analysis, or
- c. At prescribed hardtime intervals.

This compressor is not enrolled in the Army Oil Analysis Program. **HARDTIME INTERVALS APPLY.**

For equipment under manufacturer's warranty, hardtime oil service intervals shall be followed. Intervals shall be shortened if lubricants are known to be contaminated or if operation is under adverse conditions such as longer than usual operating hours, extended idling periods, extreme heat, or dust.

LUBRICANT

ENGINE CRANKCASE OIL AND FILTER (O) (See note 1)	SEE TABLE	INTERVAL 100 H INITIAL BREAK-IN 250 H THEREAFTER
CONTROL LINKAGE (O)	OE/HDO-30	100H
COMPRESSOR OIL AND FILTER (O) (See note 2)	SEE TABLE	100 H INITIAL BREAK-IN 500 H THEREAFTER
NOSE REEL (O)	GAA	100 H
SERVICE VALVES (O)	GAA	1000 H

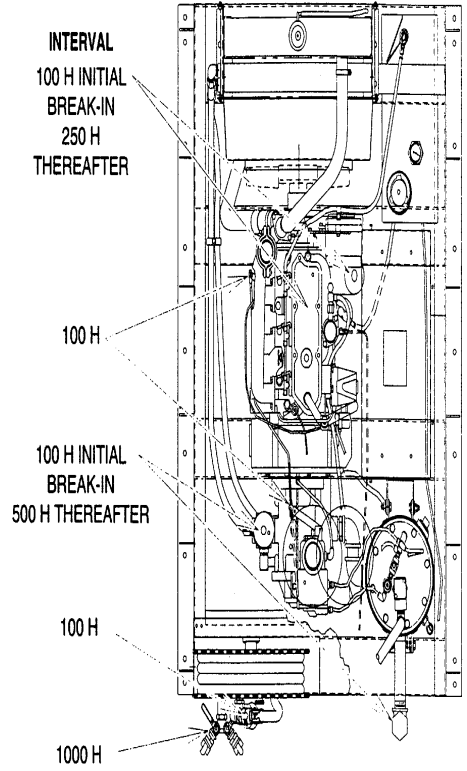

LUBRICATION POINT	CAPACITY/ AMOUNT	LUBRICANT MIL. SYMBOL (NATO CODE) SPECIFICATION	EXPECTED TEMPERATURES	MAN-HOUR
ENGINE CRANKCASE (O)	9 QUARTS (8.52 L)	OE/HDO-30 (0-238) MIL-L-2104	+40 TO +125°F +10 TO +52°C	.5
		OEA (D-183) MIL-L-46167	-55 TO +40°F -67 TO +10°C	
COMPRESSOR (O)	20 QUARTS (18.9 L)	OE/HDO-30 (0-238) MIL-L-2104	+40 TO +125°F +10 TO +52°C	.5
		OEA (D-183) MIL-L-46167	-55 TO +40°F -67 TO +10°C	
CONTROL LINKAGE (O)	OIL CAN (SPARINGLY)	OE/HDO-30 (0-238) MIL-L-2104	ALL	1
SERVICE VALVES (O)				1
HOSE REEL (O)				GAA (G-403) MIL-G-10924

Before you start your lube service:

ALWAYS

- a. Clean grease fittings before lubrication.
- b. Use the lubrication order as a guide.

NEVER

- a. Use wrong type/grade grease.
- b. Use too much lubricant

**NOTES:**

1. Check engine oil level (C) daily before startup. Oil level is checked at dipstick. Add oil if level drops below lower marks on dipstick. DO NOT overfill. Replace engine oil filter (O) at 100 hours for initial break-in and at 250 hours thereafter.
2. Check compressor oil level (O) quarterly. Remove oil filler cap and check oil level pipe. Proper quantity is indicated by lubricating oil level being visible in elbow. Add oil if no oil is visible. Replace compressor oil filter (O) at 100 hours for initial break-in and at 500 hours thereafter.

Copy of this lubrication order will remain with the equipment at all times; instructions contained herein are mandatory.

By Order of the Secretary of the Army:

Official:

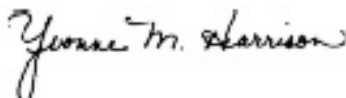

Official:

YVONNE M. HARRISON  
Administrative Assistant to the  
Secretary of the Army  
01335

DENNIS J. REIMER  
General, United States Army  
Chief of Staff

**DISTRIBUTION:**

To be distributed in accordance with DA Form 12-25-E, block no. 6337, requirements for LO 9-4310-397-12.

RECOMMENDED CHANGES TO EQUIPMENT TECHNICAL PUBLICATIONS



THEN... JOT DOWN THE DOPE ABOUT IT ON THIS FORM, CAREFULLY TEAR IT OUT, FOLD IT AND DROP IT IN THE MAIL!

**SOMETHING WRONG WITH THIS PUBLICATION?**

FROM: (PRINT YOUR UNIT'S COMPLETE ADDRESS)

DATE SENT

PUBLICATION NUMBER

PUBLICATION DATE

PUBLICATION TITLE

BE EXACT... PIN-POINT WHERE IT IS

PAGE NO.	PARA-GRAPH	FIGURE NO.	TABLE NO.
----------	------------	------------	-----------

IN THIS SPACE TELL WHAT IS WRONG AND WHAT SHOULD BE DONE ABOUT IT:

TEAR ALONG PERFORATED LINE

PRINTED NAME, GRADE OR TITLE, AND TELEPHONE NUMBER

SIGN HERE:

DA FORM 2028-2  
1 JUL 79

PREVIOUS EDITIONS ARE OBSOLETE.

P.S.—IF YOUR OUTFIT WANTS TO KNOW ABOUT YOUR RECOMMENDATION MAKE A CARBON COPY OF THIS AND GIVE IT TO YOUR HEADQUARTERS.

**PIN: 074513-000**